

GOLDBELL model SUPER-SS

Fully stainless steel check weighing scale



Features:

- Main feature: sealed circuit panel, loadcell & charger.
- Load cell is Water-proof protected.
- Stainless steel housing.
- Red LED display
- Platform size: 23cm x 19cm.
- Counting function with 4 measuring units
- Stability function setting
- Built-in rechargeable battery
- The protection grade is specified as IP67.
- Optional: RS232/485 communication interface

Capacity & Accuracy:

- 6kg x 0,5g
- 30kg x 1g

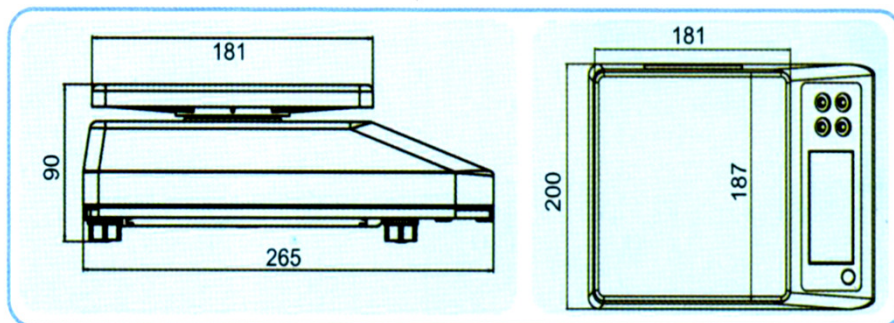

Waterproof loadcell protected

